

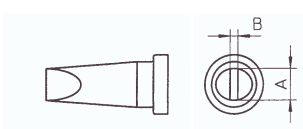
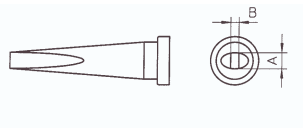
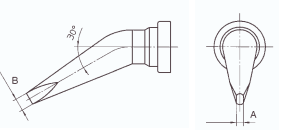
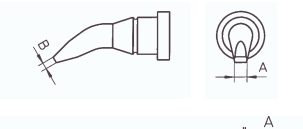
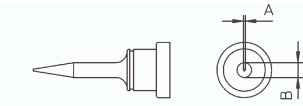
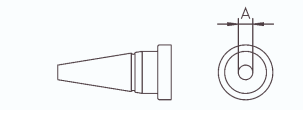
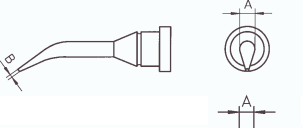
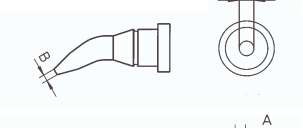
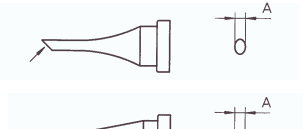

Soldering Irons and Tips

Electronic Controlled Low Voltage Soldering Irons

Soldering Tips for WSP 80, WSP 80IG, WSP 80FE, FE 75 and MPR 80

	Order No.	Model	Description	Width A	Thickness B	Length L
	005 44 437 99	LT H	Chisel	0,8 mm	0,4 mm	12,5 mm
	005 44 430 99	LT HHPB	Chisel*	0,8 mm	0,4 mm	12,5 mm
	005 44 403 00	LT A	Chisel	1,6 mm	0,7 mm	12,5 mm
	005 44 431 99	LT AHPB	Chisel*	1,6 mm	0,7 mm	12,5 mm
	005 44 470 00	LT ALF	Chisel**	1,6 mm	0,7 mm	12,5 mm
	005 44 405 00	LT B	Chisel	2,4 mm	0,8 mm	12,5 mm
	005 44 432 99	LT BHPB	Chisel*	2,4 mm	0,8 mm	12,5 mm
	005 44 446 00	LT BLF	Chisel**	2,4 mm	0,8 mm	12,5 mm
	005 44 407 00	LT C	Chisel	3,2 mm	0,8 mm	12,5 mm
	005 44 447 00	LT CLF	Chisel**	3,2 mm	0,8 mm	12,5 mm
	005 44 409 00	LT D	Chisel	4,6 mm	0,8 mm	12,5 mm
	005 44 448 00	LT DLF	Chisel**	4,6 mm	0,8 mm	12,5 mm
	005 44 483 00	LT DHPB	Chisel*	4,6 mm	0,8 mm	12,5 mm
	005 44 413 00	LT K	Chisel long	1,2 mm	0,4 mm	20,0 mm
	005 44 414 00	LT L	Chisel long	2,0 mm	1,0 mm	20,0 mm
	005 44 476 00	LT LLF	Chisel long**	2,0 mm	1,0 mm	20,0 mm
	005 44 415 00	LT M	Chisel long	3,2 mm	1,2 mm	20,0 mm
	005 44 477 00	LT MLF	Chisel long**	3,2 mm	1,2 mm	20,0 mm
	005 44 420 99	LT HX	Chisel bent 30°	0,8 mm	0,4 mm	17,0 mm
	005 44 443 00	LT ALX	Chisel bent 30°	1,6 mm	0,7 mm	17,0 mm
	005 44 442 00	LT BX	Chisel bent 30°	2,4 mm	0,8 mm	17,0 mm
	005 44 427 00	LT AX	Chisel bent 30°	1,6 mm	0,8 mm	13,5 mm
	005 44 480 00	LT AXLF	Chisel bent 30°	1,6 mm	0,8 mm	13,5 mm
	005 44 469 00	LT MXLF	Chisel bent 30° **	3,2 mm	0,8 mm	19,3 mm
	005 44 436 99	LT 1S	Round slim	Ø 0,2 mm		15,0 mm
	005 44 488 99	LT 1SA	Round slim	Ø 0,5 mm		15,0 mm
	005 44 435 99	LT 1	Round	Ø 0,25 mm		12,5 mm
	005 44 489 99	LT 1A	Round	Ø 0,5 mm		13,0 mm
	005 44 404 00	LT AS	Round	Ø 1,6 mm		12,5 mm
	005 44 471 00	LT ASLF	Round**	Ø 1,6 mm		12,5 mm
	005 44 411 00	LT CS	Round	Ø 3,2 mm		12,5 mm
	005 44 474 00	LT CSLF	Round**	Ø 3,2 mm		12,5 mm
	005 44 426 99	LT 1SLX	Round slim bent 30°	Ø 2,0 mm	0,4 mm	20,5 mm
	005 44 428 00	LT 4X	Round bent 30°	Ø 1,2 mm	0,4 mm	16,5 mm
	005 44 425 99	LT 1X	Round bent 30°	Ø 0,4 mm		12,5 mm
	005 44 439 99	LT 4	Round sloped 45° slim	Ø 1,2 mm		15,0 mm
	005 44 408 00	LT F	Round sloped 45°	Ø 1,2 mm		12,5 mm

Soldering Irons and Tips

Electronic Controlled Low Voltage Soldering Irons

Soldering Tips for WSP 80, WSP 80IG, WSP 80FE, FE 75 and MPR 80

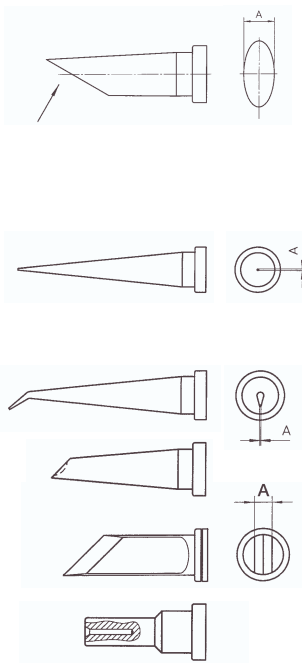

Order No.	Model	Description	Width A	Thickness B	Length C
005 44 487 00	LT AALF	Round sloped 60° long	1,6 mm	4,0 mm	13,0 mm
005 44 444 00	LT BB	Round sloped 45° long	2,4 mm	4,0 mm	17,0 mm
005 44 472 00	LT BBLF	Round sloped 45° long**	2,4 mm	4,0 mm	17,0 mm
005 44 445 00	LT CC	Round sloped 45° long	3,2 mm	6,0 mm	17,0 mm
005 44 473 00	LT CCLF	Round sloped 45° long**	3,2 mm	6,0 mm	17,0 mm
005 44 478 00	LT DDLF	Round sloped 45° long**	4,6 mm	6,0 mm	20,0 mm
005 44 423 99	LT 1L	Conical long	Ø 0,2 mm		25,0 mm
005 44 406 99	LT S	Conical long	Ø 0,4 mm		15,0 mm
005 44 482 00	LT TLF	Conical long**	Ø 0,6 mm		13,0 mm
005 44 481 00	LT OLF	Conical long**	Ø 0,8 mm		17,0 mm
005 44 424 99	LT 1LX	Conical long bent	Ø 0,2 mm		25,0 mm
005 44 410 00	LT GW	Gull wing 45°	Ø 2,3 mm	3,2 mm	18,0 mm
005 44 475 00	LT GWLF	Gull wing 45° **	Ø 2,3 mm	3,2 mm	18,0 mm
005 44 479 00	LT KNLF	Soldering knife tip**	6,2 mm		16,5 mm
005 44 416 00		LT Measuring tip for thermo element 0,5 mm			13,0 mm
005 44 449 99		LT Screw in tip with M4 outside thread			8,0 mm

• **HPB solder** = solder with high consumption of lead for special high melting applications

****Lead free solder** = the LF soldering tips have thicker layer of iron. This improves the lifetime and makes them ideal of working with lead free solder. Regular soldering tips can be used with lead free solder but it reduces their lifetime for physical reasons.

SMD Soldering Tips for WSP 80

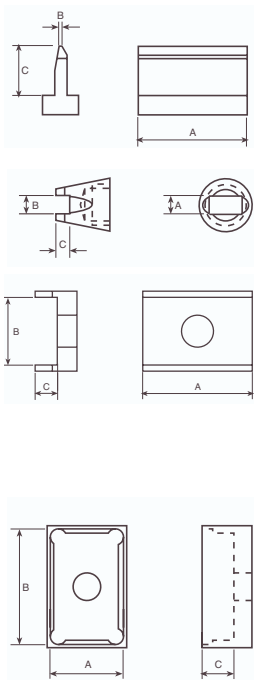

Order No.	Model	Description	Width A	Thickness B	Length C
LTSMT01	LT SMT01	Blade	10,4 mm	0,6 mm	7,1 mm
LTSMT02	LT SMT02	Blade	16,8 mm	0,6 mm	7,1 mm
LTSMT03	LT SMT03	Blade	20,8 mm	0,6 mm	7,1 mm
LTSMT04	LT SMT04	Slot	1,8 mm	3,4 mm	1,8 mm
LTSMT05	LT SMT05	Slot	1,5 mm	2,3 mm	1,8 mm
LTSMT06	LT SMT06	Slot	2,5 mm	1,7 mm	1,4 mm
LTSMT07	LT SMT07	Slot	2,3 mm	4,5 mm	1,8 mm
LTSMT08	LT SMT08	Tunnel	4,6 mm	5,1 mm	2,3 mm
LTSMT09	LT SMT09	Tunnel	10,4 mm	5,1 mm	2,3 mm
LTSMT10	LT SMT10	Tunnel	11,5 mm	6,9 mm	2,3 mm
LTSMT11	LT SMT11	Tunnel	13,2 mm	9,5 mm	3,2 mm
LTSMT12	LT SMT12	Tunnel	15,8 mm	9,5 mm	3,2 mm
LTSMT13	LT SMT13	Tunnel	18,3 mm	9,5 mm	3,2 mm
LTSMT14	LT SMT14	Tunnel	18,8 mm	9,0 mm	3,2 mm
LTSMT15	LT SMT15	Quad	2,7 mm	7,7 mm	3,8 mm
LTSMT16	LT SMT16	Quad	10,4 mm	10,4 mm	3,8 mm
LTSMT17	LT SMT17	Quad	12,7 mm	12,7 mm	3,8 mm
LTSMT18	LT SMT18	Quad	13,7 mm	8,6 mm	3,8 mm
LTSMT19	LT SMT19	Quad	19,1 mm	19,1 mm	3,8 mm
LTSMT20	LT SMT20	Quad	23,2 mm	17,3 mm	3,8 mm
LTSMT21	LT SMT21	Quad	24,5 mm	24,5 mm	3,8 mm
LTSMT22	LT SMT22	Quad	29,6 mm	29,6 mm	3,8 mm